

# E-35 C/D DUE

Single lever cartridge  
Standard 35mm

**08E35LAZ30**



## Technical specifications

Nut torque/Pitch M1,5		10-12 N.m
Opening angle		25°
Rotation angle		90°
Working pressure (recommended)		1 - 5 bar
Burst pressure		28 ÷ 35 bar
Life cycle	EN 817 ASME 112.18.1 M	70,000 cycles 500,000 cycles
Sensitivity		10° ÷ 11° angle
Fidelity		4,51 °C
Constant 63°C & 50°C (6 l/min-3 l/min)		< 4°C - < 6°C
Max. Hot water		90 °C
Max. Hot water recommended		60 - 65 °C
Flow rate at 3 bar		
Free flow		25,00 l/min
C-Restrictor		19,50 l/min
Operation torque		
Open - close		0,19 ÷ 0,25 Nm
Turn left-right		0,22 ÷ 0,33 Nm

## Flow

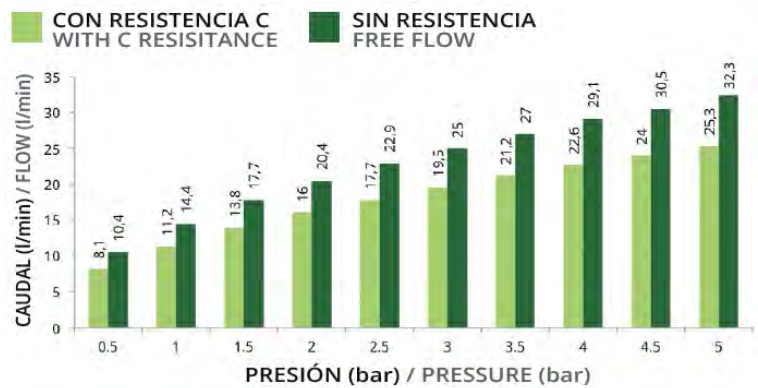

## Sensitivity

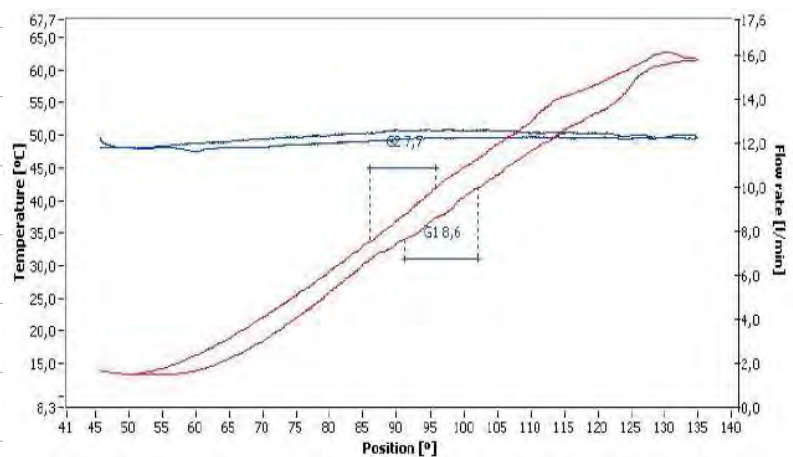

For Sanitary Certification refer to DOC. PS2.4.11

Single lever cartridge standard 35mm

E-35 C/D DUE

Technical dimensions

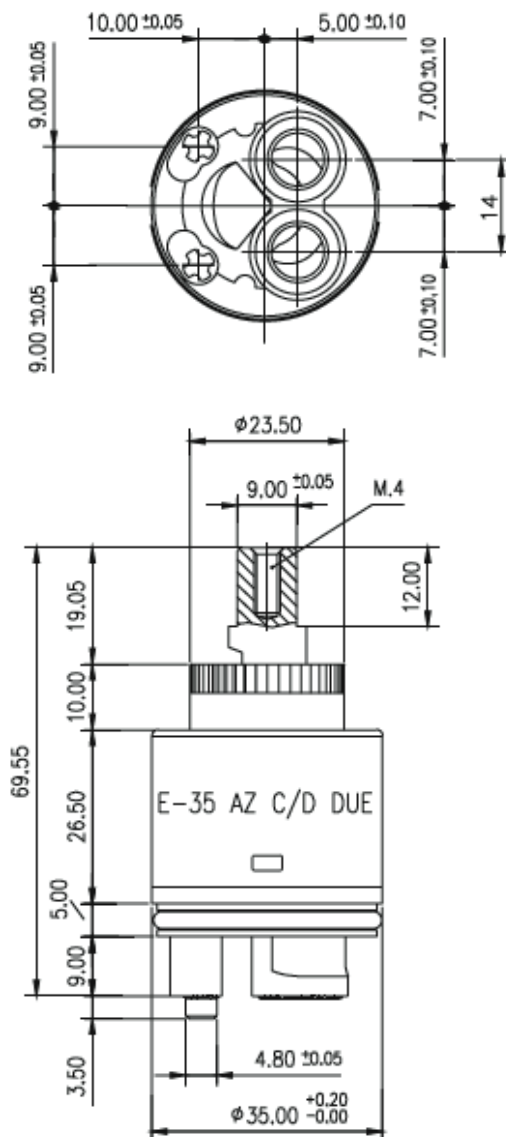

Machining prescription

